

***Keogh Plans, Top-Heavy Plans and
Controlled Groups***

Keogh Plans, Top-Heavy Plans and Controlled Groups

Table of Contents

I.	INTRODUCTION.....	1
	A. Unincorporated Entities May Establish a Qualified Plan.....	1
	B. Individuals or Entities That May Establish Keogh Plans.....	1
II.	RULES APPLICABLE TO KEOGH PLANS ONLY	3
	A. Qualification Requirement Applicable to Keogh Plans.	3
	B. Deduction Requirements.....	3
	C. Life Insurance.	3
	D. Loans from a Keogh Plan Prior to 2002.....	4
	E. Distributions from Keogh Plan.	4
	F. Contributions to a Keogh Plan.	4
	G. Treatment as Cash or Deferred Arrangement.	6
	H. 401(k) Plan for Unincorporated Employers.....	6
III.	CONTROLLED GROUPS AND AFFILIATED SERVICE GROUPS. I.R.C. §§ 414(b), (c) and (m).....	7
	A. Controlled Groups. I.R.C. §§ 414(b) and (c) and 1563(a).	7
	B. Affiliated Service Groups. I.R.C. § 414(m).	10
IV.	TOP-HEAVY PLANS	12
	A. Top-Heavy Plans (Sixty Percent of Accrued Benefits or Account Balances Go to Key Employees).....	12
	B. Key Employees. I.R.C. § 416(i)(1).	14
	C. Minimum Benefits for Non-Key Employees (Defined Benefit Plans).	14
	D. Minimum Contribution for Non-Key Employees (Defined Contribution Plans).....	15
	E. Vesting/Participation. I.R.C. § 416(b)(1).....	15

Keogh Plans, Top-Heavy Plans and Controlled Groups

I. INTRODUCTION

A. Unincorporated Entities May Establish a Qualified Plan.

1. I.R.C. § 401(a)(2) indicates that a qualified plan must be established by an employer for the exclusive benefit of the employees or their beneficiaries.
2. Although a sole-proprietor or partnership meets the definition of an employer, it does not necessarily follow that the owners of such entities fall within the common law definition of employees. Thus, I.R.C. § 401(c)(1) provided that the term “employee” encompasses for any taxable year any individual who has “earned income.”
3. Since “earned income” means net earnings from self-employment in a trade or business in which personal services are a material income producing factor, I.R.C. § 401(c)(2), a limited partner or a partner *who only makes a capital contribution* to the partnership is ineligible to participate in a qualified plan. Reg. § 1.401-10(c)(3).
4. In determining net earnings (and thus earned income) all business expenses must be deducted. This includes not only contributions made to a qualified plan for regular employees, but also contributions made on behalf of the self-employed person for the applicable plan year. I.R.C. § 401(c)(2)(A)(v); Reg. § 1.401-10(c)(2)(iii). Earned income is computed after the deduction allowed to the self-employed individual for fifty percent of the individual’s self-employment tax. I.R.C. §§ 164(f), 401(c)(2)(A)(vi) and 1401.

B. Individuals or Entities That May Establish Keogh Plans.

1. A “self-employed individual” is anyone who pays self-employment tax under the federal Social Security system or anyone who may elect to come under the Social Security system and pay self-employment tax.
2. An “owner-employee” is a self-employed individual who either owns the entire interest in a sole-proprietorship or owns more than ten percent of either the capital or profit interest in a partnership or an LLC. In either event, the owner-employee must have earned income. I.R.C. § 401(c)(3).

- a. For purposes of the ten percent ownership rule, the actual method used for dividing profits, as opposed to a different method stated in a partnership agreement, is determinative. *See Hill, Farrer & Burrill*, 67 TC 411 (1976).
- b. Since a partnership is treated as the employer of each partner, the plan must be established by the partnership and not by the individual partners. I.R.C. § 401(c)(4).
- c. Since limited liability companies (LLCs) are not incorporated, plans sponsored by LLCs are Keogh plans and the members/owners are treated as owner employees.
- d. Shareholders in professional or S corporations *are not* treated as owner-employees. Reg. § 1.401-1(b)(3).
- e. Although full-time life insurance agents are self-employed pursuant to the common law definition of an employee, they may be treated as common law employees for social security and, thus, qualified plan purposes. Reg. § 1.401-10(b)(3) and I.R.C. § 7701(a)(20). The Supreme Court has held that the traditional common law definition of employee is controlling in the determination of whether an individual is an “employee” for ERISA purposes and, thus, eligible for ERISA protections. *Nationwide Mut. Ins. Co. v. Darden*, 112 S. Ct. 1344 (1992). A general agent may establish a qualified plan for himself and his employees. IRS Pub. 7789, 2(j)(4).
- f. A self-employed person who also has a job with an unrelated employer as a common law employee may establish a qualified plan for his self-employment income. *See* Reg. § 1.401-10(b)(3)(ii).
- g. The withdrawal of Prop. Reg. § 1.414(o)-1(g) may permit an inside corporate director to use a Keogh plan. Rev. Rul. 72-86 stated that compensation for services as a corporate director is treated as self-employment income for federal tax purposes, even if the corporate director is also an officer, executive or employee. Therefore, contributions to a Keogh plan may be based on the compensation received by the corporate director (for the director services) and will not affect the amounts contributed to a corporate retirement plan on the corporate director’s behalf as an employee of the corporation. *Note*: an individual director of a closely held corporation could be a member of a controlled group or an affiliated service group. In such a case, the director would not be permitted to establish a Keogh plan for his self-employment income.

II. RULES APPLICABLE TO KEOGH PLANS ONLY

A. Qualification Requirement Applicable to Keogh Plans.

1. In the event that an owner-employee controls more than one business, contributions and benefits under a qualified plan must be provided to all employees that are at least as favorable as those provided to the owner-employees. I.R.C. § 401(d)(2).

B. Deduction Requirements.

1. Contributions to an owner-employee may only be made to the extent of earned income (previously defined) derived from the trade or business pertaining to the established plan. I.R.C. § 401(d).
2. A contribution to a qualified plan by a self-employed person may not be used to create a net operating loss. I.R.C. § 172(d)(4)(D).
3. A self-employed person receives a deduction for contributions made to a qualified plan irrespective of whether he itemizes. With respect to a partnership, such deductions are taken by the individual partners. I.R.C. § 62(a)(7); Reg. § 1.62; § 1.404(e)-1(A)(f).
4. Social Security treatment of self-employed person's contributions to Keogh plan.

Contributions made by a self-employed individual on the individual's own behalf to a qualified plan, SEP or IRA that are deductible under §§ 404(a), 404(h) or 219(a) respectively are nonetheless *not* deductible for purposes of computing the individual's self-employment income as defined in § 1402 for purposes of the Self-Employment Contributions Act of 1954 (SECA). GCM39807(1990).

C. Life Insurance.

1. Contributions for life insurance made by the employer for a self-employed individual are not deductible. Consequently, such contributions are subtracted from the total contributions to arrive at the deductible amount. I.R.C. § 404(e); Reg. § 1.404(e)-1(A)(g). The subtracted amount of life insurance, however, is the P.S. 58, as opposed to the actual amount. In other words, if premiums on life insurance for an owner-employee are paid by a Keogh plan the P.S. 58 amount of such insurance is includable in the income of the owner-employee.
2. The P.S. 58 amount is not included in the owner's cost basis for the insurance. Reg. § 1.72-16(b)(4).

D. Loans from a Keogh Plan Prior to 2002.

Although the same rules apply to loans from Keogh plans with respect to common law employees, owner-employees do not fall within the prohibited transaction exception. Thus, such loans were prohibited. The same rule applies to S corporations. I.R.C. § 4975(d). Thus, prior to 2002 loans were not permitted from a Keogh plan to a ten percent or more owner or from an S corporation plan to a five percent or more owner. EGTRRA repeals this loan prohibition for loans made for plan years beginning after December 31, 2001.

E. Distributions from Keogh Plan.

1. A distribution from a Keogh plan may constitute a lump-sum distribution, but not if the distribution is because of separation from service for a self-employed individual prior to age 59½ for reasons other than death or disability. I.R.C. § 402(e)(4)(D).
2. Keogh plan distributions may be rolled over to another qualified plan or to an IRA if such distributions constitute eligible rollover distributions. I.R.C. § 402(c)(4).

F. Contributions to a Keogh Plan.

1. Since earned income (Schedule C or from the K-1 for a partner) is defined in a manner that excludes contributions made on behalf of an owner-employee to a qualified plan, the percentage of contributions pertaining to annual additions must be reduced accordingly. To do this, an algebraic formula must be used. This formula is the self-employed's contribution percentage divided by one plus the self-employed's contribution percentage or, where C = the self-employed's contribution rate: The formula is $C\% / (1 + C\%)$.
2. This reduction is the equivalent to adding 100% to the applicable percentage, and dividing the applicable percentage by that figure. Thus, the contribution for an owner-employee to a defined contribution plan (e.g. a profit sharing plan) generally may not exceed 25%/1.25, or 20%.
3. Calculating deductions based on earned income.

In the case of a plan under which employer contributions are expressed as a percentage of the compensation of each participant (e.g., a money purchase pension plan), the requirement that net earnings be reduced by the deduction for contributions is satisfied if the plan's stated rate of contribution is reduced, for each self-employed participant, to a rate determined by dividing the stated rate by the integer one plus that stated rate (expressed as a decimal). For example, if the plan calls for an employer contribution on behalf of each participant equal to ten percent of that participant's compensation, the rate for a self-employed

participant is reduced to 9.0909%—that is, ten percent divided by 1.10.

The following chart converts the plan’s contribution rate to the self-employed person’s rate.

Self-Employed Person’s Rate Table

<i>Column A</i> <i>If the Plan Contribution Rate is</i> <i>(shown as a %)</i>	<i>Column B</i> <i>The Self-Employed</i> <i>Person's Rate is</i> <i>(% shown as a decimal)</i>
1	.009901
2	.019608
3	.029126
4	.038462
5	.047619
6	.056604
7	.065421
8	.074074
9	.082569
10	.090909
11	.099099
12	.107143
13	.115044
14	.122807
15	.130435
16	.137931
17	.145299
18	.152542
19	.159664
20	.166667
21	.173554
22	.180328
23	.186992
24	.193548
25	.200000

4. One-half of the self-employment tax must also be subtracted from the net profit.
5. The I.R.C. § 401(a)(17) \$200,000 (adjusted, \$245,000 fo4 2009) limit on compensation may be subject to the reduced percentages. In other words, an employee in a corporate profit-sharing plan can receive a contribution of 25% of \$200,000 while an owner-employee in a Keogh profit-sharing plan could be limited to 20% of \$200,000 depending on the manner in which the Plan defines “earned income.” See Reg. § 1.401(a)(17)-1(b)(16) examples 4 and 5.

6. If a profit-sharing plan calls for discretionary contributions and then provides for an allocation formula, the allocation formula is based on total earnings less the contribution made to the plan. Thus, if a ten percent contribution was made based on covered compensation of \$100,000, current compensation (including earned income) will be \$90,000. Allocations would then be made based upon the percentage that a participant's compensation bears to the \$90,000 amount.

G. Treatment as Cash or Deferred Arrangement.

1. IRS Notice 88-127 notes that Treas. Reg. § 1.401(k)-1(a)(6)(ii) provides that an arrangement that directly or indirectly permits individual partners to vary the amount of contributions made to qualified retirement plans on their behalf will constitute a cash or deferred arrangement (CODA) with respect to such partners. Thus, if partners are permitted to elect in and out of a Keogh plan, the plan will be treated as a § 401(k) plan. If the plan is not a § 401(k) plan, it will probably lose its tax-qualified status.
2. Reg. § 1.401(k)-1(a)(3)(iv) provides that a one-time irrevocable election made by an employee to have the employer contribute a specified amount or percentage of compensation to a plan for the duration of the employee's employment with the employer will not be treated as having been made pursuant to a CODA if the election is made upon commencement of employment or upon the employee's first becoming eligible under any plan of the employer. Individuals may also make a one-time election to participate or not participate in a plan if such election is made on or before December 23, 1994.
3. The IRS has indicated that these rules may also be applicable to five percent or more shareholders in corporate retirement plans. IRS EP/EO Special Technical Advisor Richard Wickersham has stated that a plan can be designed or amended to exclude specific categories of employees (*e.g.*, president or treasurer) as long as there is no personal waiver by an owner.

H. 401(k) Plan for Unincorporated Employers.

1. Unincorporated businesses may use § 401(k) plans as a benefit program for employees. The calculations involved are more difficult, since the self-employed individual's (either a sole proprietor or partner) compensation is reduced by the contributions made on behalf of common-law employees. Also, the self-employed individual's compensation must be reduced by one-half of the Social Security contribution.

III. CONTROLLED GROUPS AND AFFILIATED SERVICE GROUPS. I.R.C. §§ 414(b), (c) and (m)

A. Controlled Groups. I.R.C. §§ 414(b) and (c) and 1563(a).

The employees of all sole proprietorships, partnerships and corporations that are members of a controlled group must be aggregated for retirement plan purposes.

1. Parent-subsidiary controlled group.

One or more chains of businesses connected through ownership with a common parent organization if at least eighty percent of the control or value of the organizations is controlled by one organization. IRC §1563(a)(1). Eighty percent (80%) control is defined as a "controlling interest". Treas. Reg. §§1.414(c)(2)(b) and 1.1563-IT.

EXAMPLE:

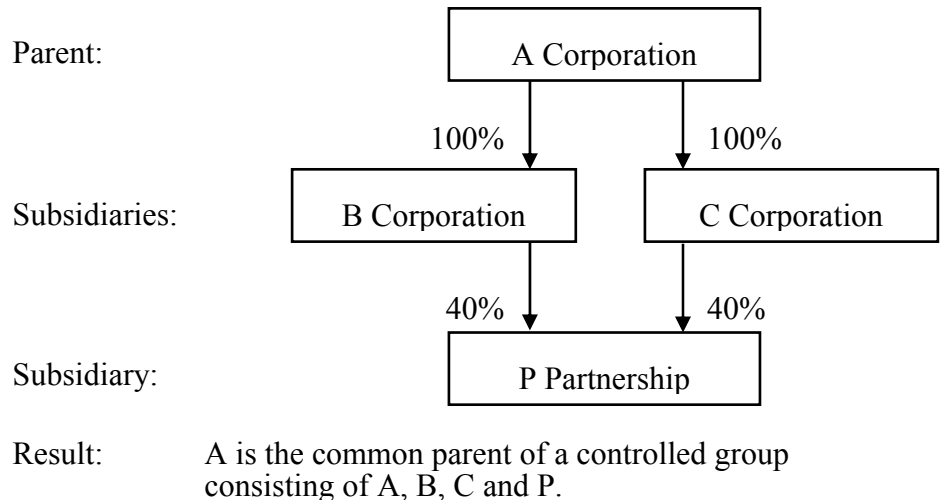

2. Brother-sister controlled group.

Two or more organizations if five or fewer persons who are individuals, estates or trusts own at least *eighty percent* of the total control or value of each entity (i.e., a controlling interest) *and* the same five or fewer persons together own more than *fifty percent* of the value or voting power of each entity (defined as "effective control"). For purposes of the fifty percent test, ownership is included only to the extent that it is identical with respect to each organization. Treas. Reg. §§1.414(c)-2(C) and 1.1563-IT(a)(3), *United States v. Vogel Fertilizer Co.*, 455 U.S. 16 (1982).

EXAMPLE:

Individuals	Corporations		Identical Ownership
	X	Y	
A	20%	33%	20%
B	20%	33%	20%
C	20%	33%	20%
D	20%	1%	1%
E	20%	0%	
TOTAL	100%	100%	61%

- a. Eighty percent common ownership for purposes of § 1563(a)(2)(A) eighty percent ownership test.
 - b. Sixty-one percent identical ownership for purposes of § 1563(a)(2)(B) more than fifty percent ownership test.
 - c. Therefore, corporations X and Y are members of a brother-sister controlled group of corporations.
3. Controlled groups for purposes of I.R.C. Section 415 limitations. I.R.C. § 415(h). Applies to parent-subsidary controlled group only.
 - a. For purposes of applying the controlled group rules of §§ 414(b) and (c) to the annual addition limitations and annual benefit limitations of § 415, the phrase "more than 50%" shall be substituted for the phrase "at least 80%" each place it appears in § 1563(a)(1).
 - b. Therefore, for purposes of determining a parent-subsidary controlled group with respect to the § 415 limitations, a controlled group will be based on one entity having more than 50% of the control or value of other organizations.
 4. Family member constructive ownership rules for controlled groups. I.R.C. § 1563(e).
 - a. Spouse.

An individual is considered as owning stock in a corporation owned directly or indirectly by or for his spouse except for an organization where all of the following conditions are satisfied for a taxable year.

- i. The individual does not own directly any stock in the corporation;
- ii. The individual is not a director or employee and does not participate in the management of such corporation;
- iii. Not more than fifty percent of such corporation's gross income for such taxable year was derived from royalties, rents, dividends, interest and annuities; and
- iv. Such stock is not subject to conditions which substantially restrict or limit the spouse's right to dispose of such stock and which run in favor of the individual or his children who have not attained the age of twenty-one years. I.R.C. § 1563(e)(5).

b. Minor children.

An individual is considered as owning stock owned, directly or indirectly, by or for his children who have not attained the age of twenty-one and, if the individual has not attained age twenty-one, the stock owned, directly or indirectly, by or for his parents. I.R.C. § 1563(e)(6)(A).

c. Adult children, parents and grandparents.

An individual who owns more than fifty percent of the voting power or fifty percent of the value of a corporation shall be considered as owning the stock in a corporation owned, directly or indirectly, by or for his parents, grandparents, grandchildren and children who have attained age twenty-one. I.R.C. § 1563(e)(6)(B).

d. There are also constructive ownership rules for stock options owned and attribution from partnerships, estates, trusts and corporations. I.R.C. §§ 1563(e)(1), (2), (3) and (4).

e. Example.

- i. Al and his children, Barb and Chuck, own X Corporation.
- ii. Al owns forty percent of X Corporation; Barb, age twenty, owns thirty percent; and Chuck, age twenty-five, owns thirty percent.
- iii. What percent of ownership in X Corporation is attributed to Al?

- (a) The thirty percent interest of Al's minor child, Barb, is attributed to Al and Al is treated as owning both his own forty percent and Barb's thirty percent for a total of seventy percent.
- (b) Because Al is treated as owning more than fifty percent, the thirty percent owned by his adult child, Chuck, is also attributed to Al and Al is considered to own 100% of X Corporation.

B. Affiliated Service Groups. I.R.C. § 414(m).

1. The affiliated service group rules of I.R.C. § 414(m) preclude a self-employed person from establishing a Keogh plan for just one entity if there are two or more organizations that constitute an affiliated service group which, for qualified plan purposes, would be aggregated into a single employer.

An affiliated service group is an entity (incorporated or unincorporated) which is either a service or management-type group. It consists of a First Service Organization (FSO) plus an A, B or A and B organization.

- a. An A organization is a shareholder or partner in the FSO *and* regularly performs services for the FSO or is associated with the FSO in performing services for third parties. I.R.C. § 414(m)(2)(A).
- b. Although a B organization does not have to be a service organization, it does have to provide services to the FSO or an A organization which their employees would normally perform. Furthermore, at least ten percent or more of the interest in the B organization has to be held by officers or highly compensated employees of the FSO or A organization. I.R.C. § 414(m)(2)(B).
- c. I.R.C. § 414(m)(6)(B) states that in determining ownership, the principles of I.R.C. § 318(a) shall apply. Under § 318(a)(1), an individual is considered to own stock owned by his spouse, children, grandchildren and parents. Additionally, § 318(a)(3) provides that if fifty percent or more in value of the stock in a corporation is owned, directly or indirectly, by or for any person, such corporation shall be considered as owning the stock owned, directly or indirectly, by or for such person.

A ORGANIZATION

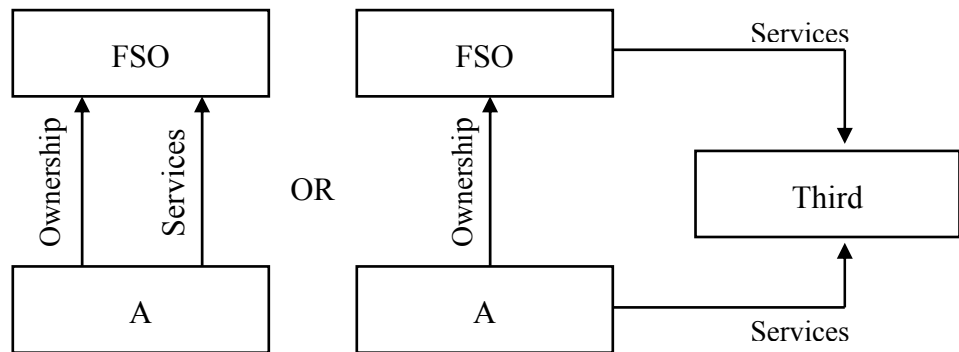

B ORGANIZATION

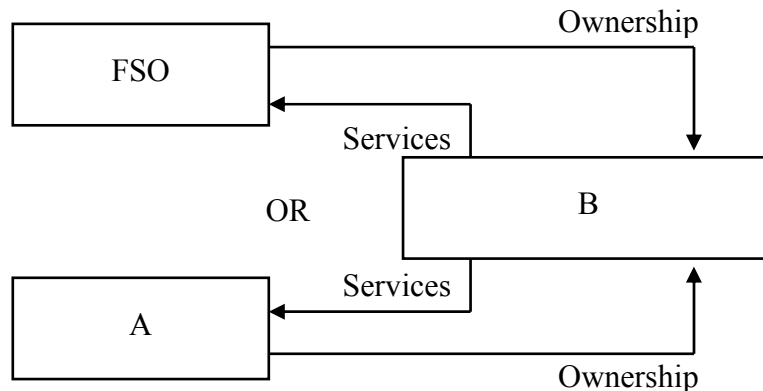

2. Section 414(m)(5) also includes “certain organizations performing management functions” in the affiliated service group definition. Section 414(m)(5) states that the term affiliated service group also includes a group consisting of:
 - a. An organization the principal business of which is performing, on a regular and continuing basis, management functions for one organization (or for one organization and other organizations related to such one organization); and
 - b. The organization (and related organizations) for which such functions are so performed by the organization described in a. (*i.e.*, the management organization).
3. Unless the controlled group or affiliated service group rules apply, a director of a corporation can establish a Keogh plan pertaining to his director’s fees. A director in his capacity as such is not considered to be an employee of the organization of which he is a director. Rev. Rule 80-87, 72-86; PLR 7839059. However, this result may not apply to a professional corporation due to the affiliated service group rules

since such corporations constitute FSOs. The sole-proprietorship would be the director, which is a service organization because capital is not a material income-producing factor (Reg. § 1.414(m)-2(f)(1)) and, thus, would be considered an A organization.

IV. TOP-HEAVY PLANS

A. Top-Heavy Plans (Sixty Percent of Accrued Benefits or Account Balances Go to Key Employees).

1. *Defined benefit* plan is top-heavy for a plan year if, as of the *determination date* (the last day of the prior plan year or, for a new plan, the last day of the initial plan year), the present value of the accumulated accrued benefits for participants who are key employees exceeds sixty percent of the present value of the accumulated accrued benefits for all employees under the plan. I.R.C. § 416(g)(1)(A)(i). All defined benefit plans of the employer must use the same accrual method or use the fractional accrual rule of I.R.C. § 411(b)(1)(C). I.R.C. § 416(g)(4)(F).

2. *Defined contribution* plan is top-heavy if the sum of the account balances of participants who are key employees as of the determination date exceeds sixty-percent of the sum of the account balances for all employees under the plan. I.R.C. § 416(g)(1)(A)(ii).

3. Top-heavy group.

Two or more plans of an employer (or controlled group of employers or affiliated service groups) are aggregated to determine whether the plans as a whole are top-heavy. Aggregation group must include: (1) any plan which covers a key employee; and (2) any other plan which enables a plan covering a key employee to meet the qualification requirements under the coverage or anti-discrimination rules. An employer may also elect to expand the group to take into account any other plan maintained by the employer, if such expanded group continues to satisfy the coverage and anti-discrimination rules. I.R.C. § 416(g)(2)(B).

a. If group is top-heavy, all plans in group are treated as top-heavy. I.R.C. § 416(g)(1)(B).

b. If group is not top-heavy, none of the plans in the group are top-heavy. Reg. § 1.416-1, T-9, T-11.

4. Both employer and employee contributions are counted for purposes of determining top-heavy status. Reg. § 1.416-1, T-28.

5. Prior to 2002, amounts distributed within past five years were also counted for determination of top-heavy status for plan years commencing prior to 2002. I.R.C. § 416(g)(3). For plan years commencing after 2001, distributions made during the one year period

ending on the determination date are taken into account for determining top heavy status. The five year rule continues to apply to in-service distributions.

6. Accrued benefits of former employees who have performed no service for the employer for five years are disregarded for purposes of testing whether a plan is top-heavy for determination of top-heavy status for plan years commencing prior to 2002. I.R.C. § 416(g)(4)(E); Reg. § 1.416-1, T-1. For plan years commencing after 2001, accrued benefits are not taken into account where the participant has not performed services for the employer during the one year period prior to the determination date.
7. A plan consisting of a cash or deferred arrangement which satisfies the design based safe harbor of IRC Section 401(k)(12) and matching contributions which satisfy the design based safe harbor of Section 401(m)(11) is not a top-heavy plan.
8. Treatment of rollovers and plan-to-plan transfers.

The rules for handling rollovers and plan-to-plan transfers depend on whether they are *unrelated* (both initiated by the employee and made from a plan maintained by one employer to a plan maintained by another employer) or *related* (a rollover or transfer either not initiated by the employee or made to a plan maintained by the same employer). A rollover or transfer made incident to a merger or consolidation of two or more plans or the division of a single plan into two or more plans will not be treated as being initiated by the employee.

- a. In the case of unrelated rollovers or transfers the plan:
 - i. Making the distribution or transfer must count the distribution as a distribution made under I.R.C. § 416(g)(3) (*i.e.*, the amount *is* included in the top-heavy calculations of the distributee plan for one year (five years for in-service distributions) after the distribution is made); and
 - ii. Accepting the rollover or transfer is not to consider the rollover or transfer as part of the accrued benefit if such rollover or transfer was accepted after December 31, 1983, but is to consider it as part of the accrued benefit if such rollover or transfer was accepted prior to January 1, 1984.
- b. In the case of related rollovers or transfers the plan:
 - i. Making the distribution or transfer does not count the distribution or transfer under I.R.C. § 416(g)(3) (*i.e.*,

the amount is *not* included in the top-heavy calculations of the distributee plan); and

- ii. Accepting the rollover or transfer counts the rollover or transfer in the present value of the accrued benefits. Rules for related rollovers and transfers do not depend on whether the rollover or transfer was accepted prior to January 1, 1984. I.R.C. § 416(g)(4); Reg. § 1.416-1, Q&A, T-32.

B. Key Employees. I.R.C. § 416(i)(1).

1. A key employee is any plan participant who, during the plan year, is:
 - a. Officers with compensation in excess of \$130,000 (\$160,000 for 2009);
 - b. A five percent owner of the employer; or
 - c. A one percent owner of the employer having annual compensation from the employer of more than \$150,000.
2. No more than fifty employees (or, if lesser, the greater of three or ten percent of the employees) shall be treated as *officers*.

Example: Bank with 100 total employees of which thirty are officers; only ten employees (ten percent of 100 total employees) will be treated as officers for top-heavy determination.

3. The definition of compensation is that used in I.R.C. § 414(q)(7).

C. Minimum Benefits for Non-Key Employees (Defined Benefit Plans).

1. Each non-key employee must accrue a benefit which, when expressed as an annual retirement benefit, is not less than *two percent of the employee's average annual compensation* (basically averaged high over five years) *multiplied by the employee's years of service* with the employer. Minimum benefit *not required to exceed twenty percent of average annual compensation*. Years of service (1) completed in a plan year beginning before 1/1/84 or (2) within which ends a plan year for which the plan is not a top-heavy plan, are not required to be taken into account in computing minimum benefit. I.R.C. § 416(c)(1). For plan years commencing after 2001, a year of service does not include any year in which no key employee or former key employee benefits under the plan.
2. Minimum benefit also applies to frozen defined benefit plans. Reg. § 1.416-1, T-5.

D. Minimum Contribution for Non-Key Employees (Defined Contribution Plans).

1. Each non-key employee participant must receive contribution of at least three percent of compensation; former participants who are now attaining less than 1000 hours of service per year and, therefore, are not currently participants, must also receive the three percent minimum contribution. I.R.C. § 416(c)(2). For plan years commencing after 2001, employer matching contributions count for purposes of minimum contributions.
2. If contribution rate is less than three percent for key employees, the contribution rate for non-key employees need not exceed the contribution rate received by the key employee who has the highest contribution rate (*e.g.*, a top-heavy profit-sharing plan could have a zero contribution for all participants). I.R.C. § 416(c)(2)(B).
3. For purposes of the top-heavy minimum contribution, the participant's "compensation" includes all compensation paid to the individual for the entire limitation year even though the individual may not have been a participant for the entire year. I.R.C. §§ 416(c)(2)(A), 414(c)(3)(A); Treas. Reg. §§ 1.416-1, 7-21; § 1.415-6(a)(3).
4. Minimum contribution requirements if an employer maintains both a defined benefit and a defined contribution plan, and both of the plans are top-heavy. Pursuant to Reg. § 1-416-1(M-12) there are four safe-harbor rules.
 - a. Satisfying the defined benefit minimum;
 - b. Utilizing the "floor offset approach" (Rev. Rul. 76-259), where the defined benefit minimum is offset by the benefits provided in the defined contribution plan;
 - c. Use the "comparability analysis" (Rev. Rul. 81-202), showing that the plans are providing benefits at least equal to the defined benefit minimum; or
 - d. Providing a minimum benefit in the defined contribution plan of at least five percent.

E. Vesting/Participation. I.R.C. § 416(b)(1).

1. 100% after three years; or

2. Six year graded vesting (with one year participation eligibility):

<u>Years of Service</u>	<u>Non-Forfeitable Percentage</u>
1	— 0%
2	— 20%
3	— 40%
4	— 60%
5	— 80%
6	— 100%

3. For plan years commencing in 2007 and thereafter, these vesting schedules are the maximum permitted vesting schedules for all defined contribution plans, regardless of the plan's top heavy status.